



## PicoBox C2



### TECHNICAL SPECIFICATIONS

#### Embedded Controller

- up to 1 GB DDR2 RAM, 533/400 MHz, 0 MB equipped
- Intel® 945GSE and ICH7M chipset
- Intel® Graphic Media Accelerator 950 VGA
- 2 x 1000 Base-T LAN, Intel® 82574L
- opt. Wireless LAN 802.11b/g
- Controller with 1 IDE port (2 x EIDE drives)
- Compact Flash Socket
- two serial ports (internal), 1 x PS/2
- Intel® DH Audio Controller, ALC662 Codec, 6 CH
- 4 x USB 2.0

#### Case

- Solid high-quality industrial case
- Case in all RAL- and NCS colors available
- on request also with your corporate logo
- Control LEDs

- Power supply:
  - via ext. 45 Watt power supply, 100-240 Volt AC
  - optionally 8 -30 Volt DC
  - or directly via 12 Volt DC
- incl. mounting rails
- Dimensions WxDxH: 180x180x55 mm

Drive bay for one 2.5" HDD (Ultra DMA/33/66/100)  
Floppy / CD/DVD-ROM via USB 2.0 external possible

2 years Warranty, Burn-In, CE compliant

### ORDER NUMBER

#### 96M1611L

- Intel® Atom™ N270 1.6GHz Fanless
- Operating temperatures: 0° - +50°C

Custom configuration on request!



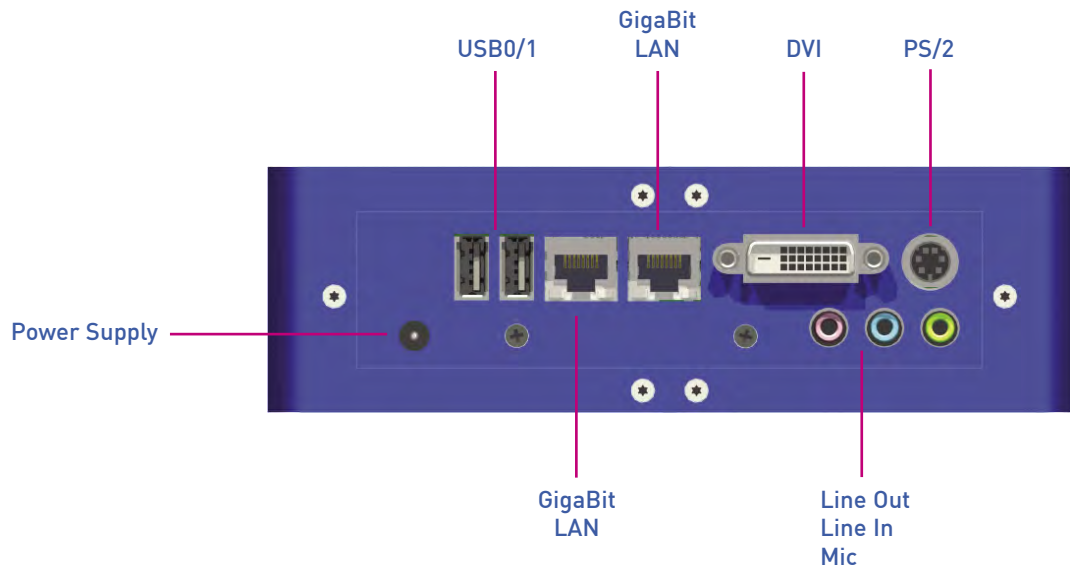

Layout 96M1611L

